



### ◆ Features

#### Features:

- Large power, without lubrication, very quiet
- Frequency 10100-36100 r/min
- Vibration force 1170-6150N
- Continuous adjustable parameters (adjustable pressure)
- Maximum operating temperature: 150°C
- Can be customized 200°C

#### Application:

- Vibrating table
- Filter sieve
- Storage bin emptying
- Material conveying
- Preventing material hanging on the wall of bin

### ◆ Ordering Code

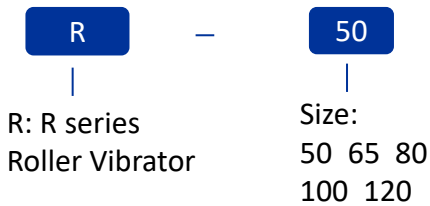

### ◆ Technical Parameter

Turbine Vibrator GT series					
Model	R50	R65	R80	R100	R120
Design	Ball Rolling Acting				
Install Method	Dos Shell 2-Φ9 Hole				
Note	Pay Attention To The Show out With Entrance And Exit				

### ◆ Dimension

Pneumatic Vibrator R series Roller Vibrator

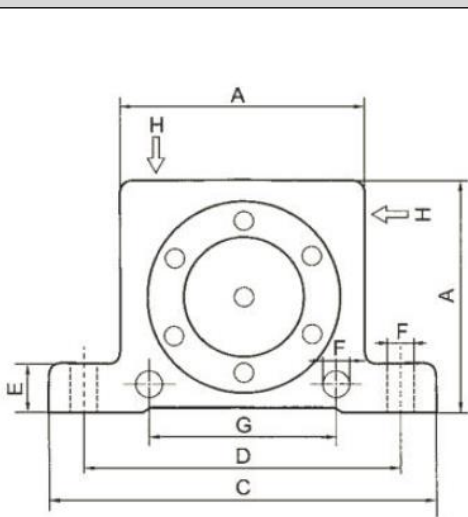

MODEL	A	Thickness	C	D	E	F	G	H	Weight
	mm	mm	mm	mm	mm	mm	mm	G	kg
R-50	50	29	86	68	12	7	40	1/8"	0.245
R-65	65	37	113	90	16	9	50	1/4"	0.54
R-80	80	43	128	104	16	9	60	1/4"	0.955
R-100	100	52	160	130	20	11	80	3/8"	1.815
R-120	120	77	194	152	24	17	100	3/8"	4.265